

LEFT SIDE VIEW

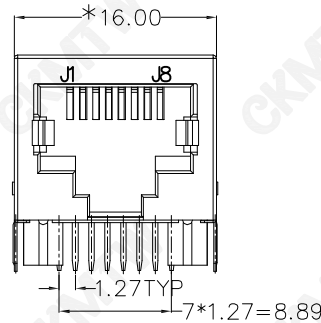

FRONT VIEW

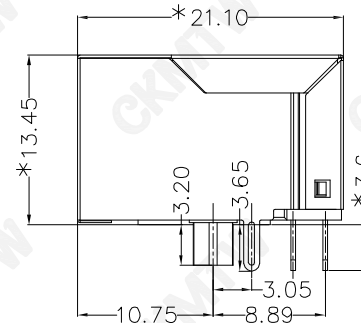

RIGHT SIDE VIEW

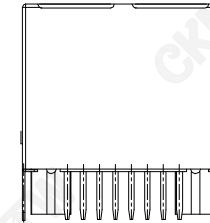

BACK VIEW

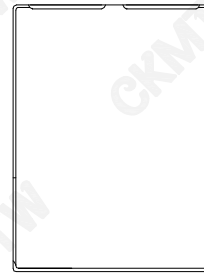

TOP VIEW

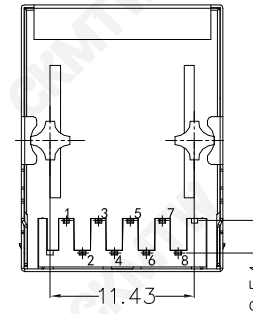

BOTTOM VIEW

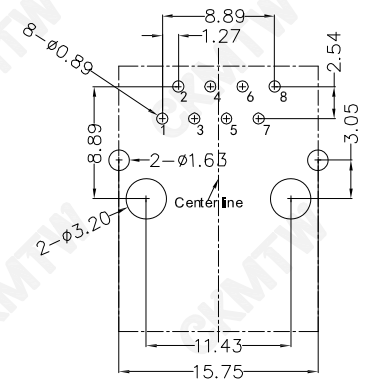

RECOMMENDED PCB LAYOUT  
VIEW WED FROM COMPONENT SIDE

**MATERIAL:**

HOUSING : PBT,UL94V-0,BLACK.  
 TERMINALS BRACKET: PBT,UL94V-0,BLACK  
 SHIELD: C2680,T=0.20MM,NICKEL PLATING ON ALL AREA.  
 TERMINAL: PHOSPHOR BRONZE C5210,T=0.35MM,  
 GOLD PLATING ON CONTACT AREA.

**MECHANICAL:**

DURABILITY: 750 CYCLES MIN.  
 MATING FORCE : 23N MAX.  
 OPERATING TEMPERATURE: -40°C~+85°C.  
 STORAGE TEMPERATURE: -40°C~+85°C.  
 ALL CRITICAL DIMENSIONS WITH "\*"

APPROVED:	DATE:	深圳市灿科盟实业有限公司 CHANKLEMENT INDUSTRYCO.,LTD			
CHECKED:	DATE:	TITLE: 百兆网口 RJ45-10P/8C TAB-DOWN H=21.1 无灯 无弹 带滤波器 十字脚			
DRAWN: L. YAN	DATE: 2020-08-10	PART. NO.	R-RJ45R08P-D007		
		UNIT	mm	SCALE	free
		FILE NO.	Ckmtw-RJ45-0267	REV.	A0

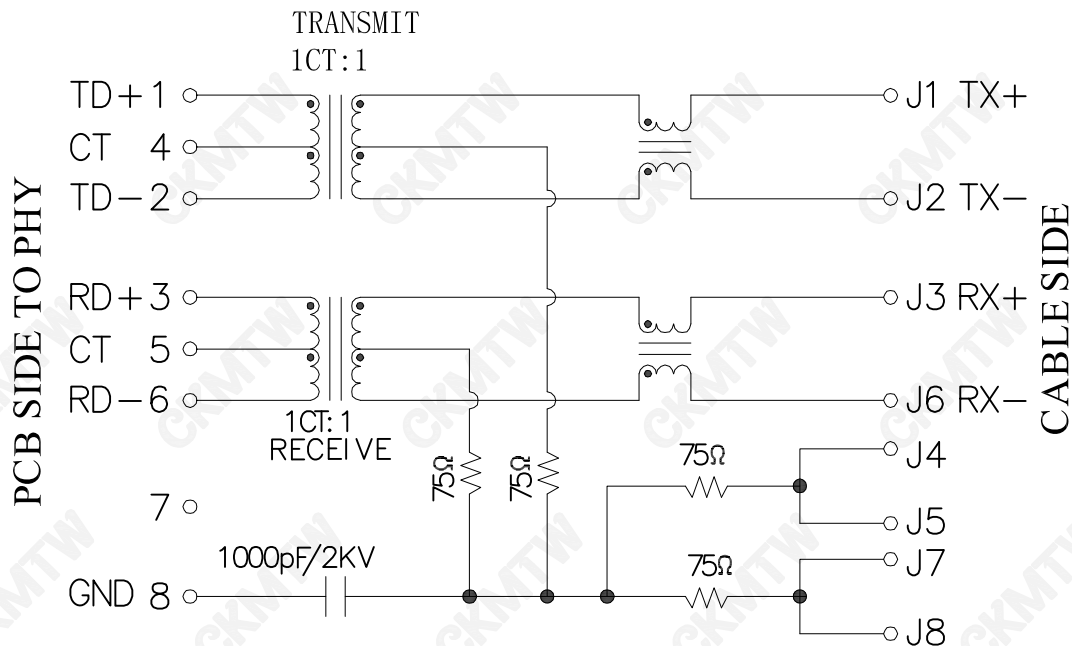

**Electrical@25°C:**

1. Turn ratio: 1~2: J1~J2=1 CT:1 CT(±2%).  
3~6: J3~J6=1 CT:1 CT(±2%).
2. OCL: 350uH Min. at 100KHz 100mV 8mA DC.
3. Insertion Loss: -1.0 dB Max 1~100MHz.
4. Return loss: -20dB Min 1~10MHz;  
-16dB Min 10~30MHz;  
-12dB Min 30~60MHz;  
-10dB Min 60~80MHz.
5. Cross talk: -40dB Min 1~30MHz;  
-35dB Min 30~60MHz;  
-30dB Min 60~100MHz;
6. CMR: -30dB Min 1~100MHz;
7. Hi-Pot: 1500V AC & 2250V DC  
6S 1mA PRI TO SEC

APPROVED:	DATE:	Ckmtw 深圳市灿科盟实业有限公司 CHANKLEMENT INDUSTRYCO., LTD			
CHECKED:	DATE:	TITLE: 百兆网口 RJ45-10P/8C TAB-DOWN H=21.1 无灯 无弹 带滤波器 十字脚			
DRAWN: L. YAN	DATE: 2020-08-10	PART. NO.	R-RJ45R08P-D007		
		UNIT	mm	SCALE	free
		FILE NO.	Ckmtw-RJ45-0267	REV.	A0